

RX Front End and Antenna Switch, v. 0.0, ed. 75

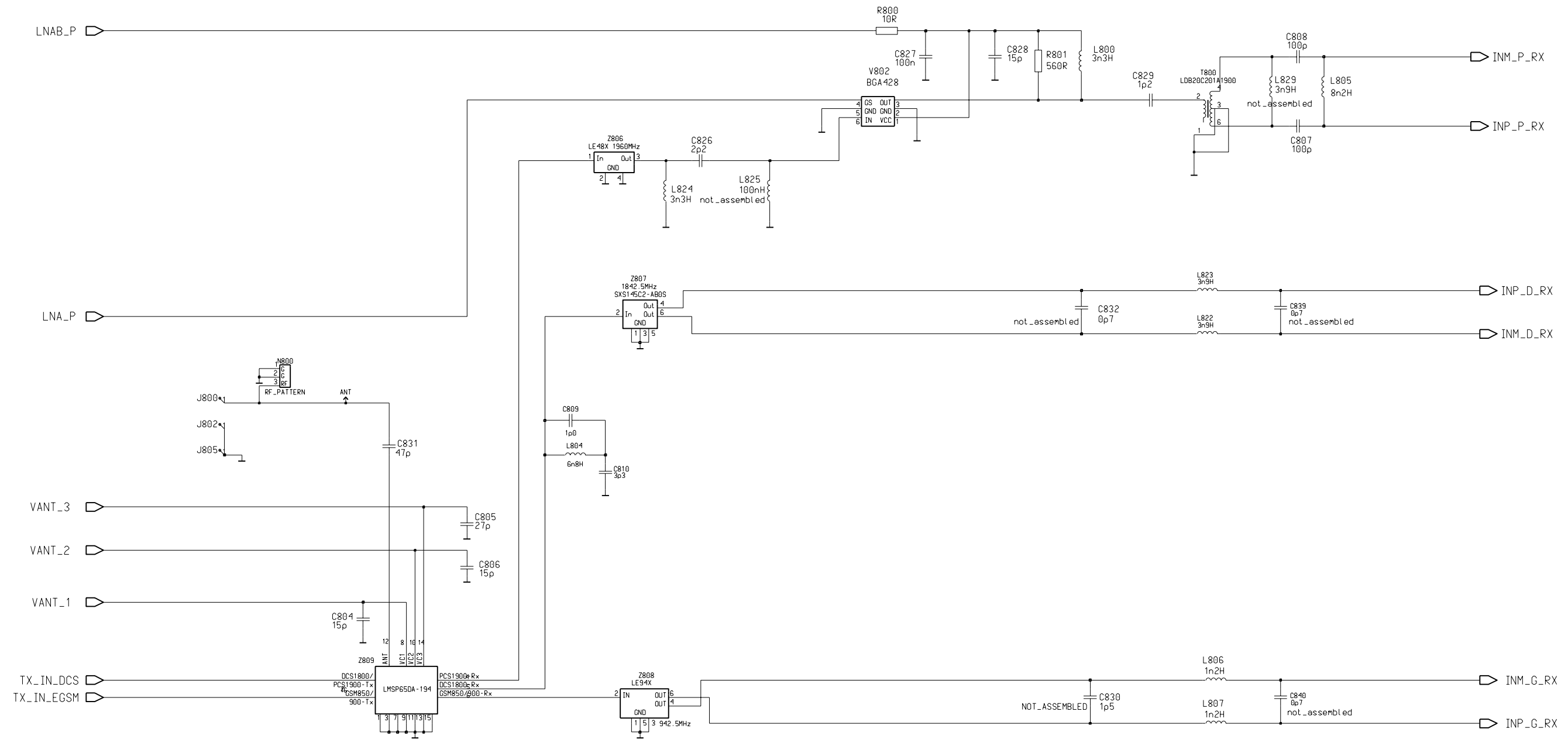

Last references :

- C840
- R807
- L828
- Z809
- V800

HELGA

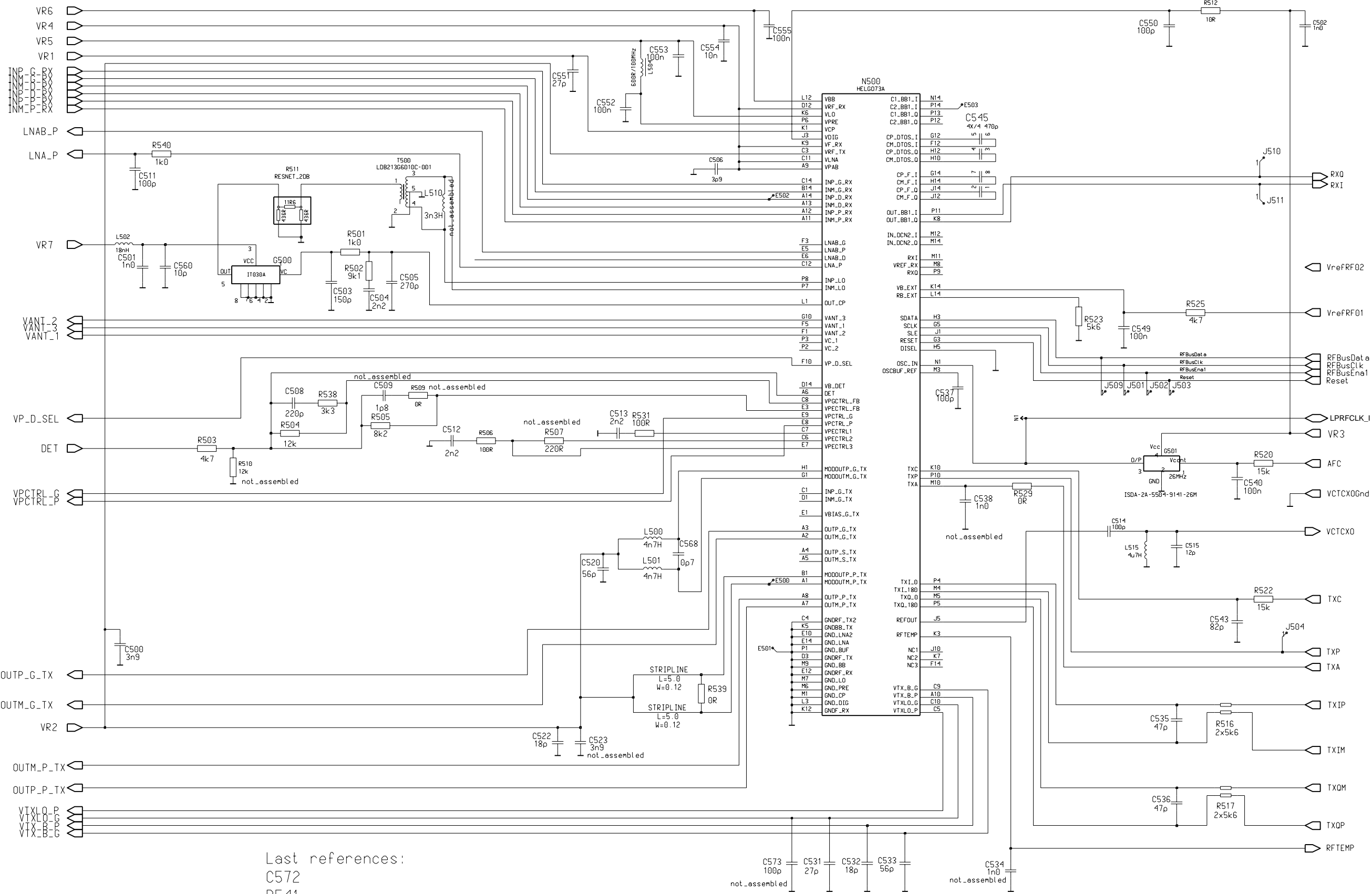

Last references:
 C572
 R541
 L511
 T501
 Tracking Filter: R534, R535

RF9204 Power Amplifier and Power Detection, v. 0.2, ed. 63

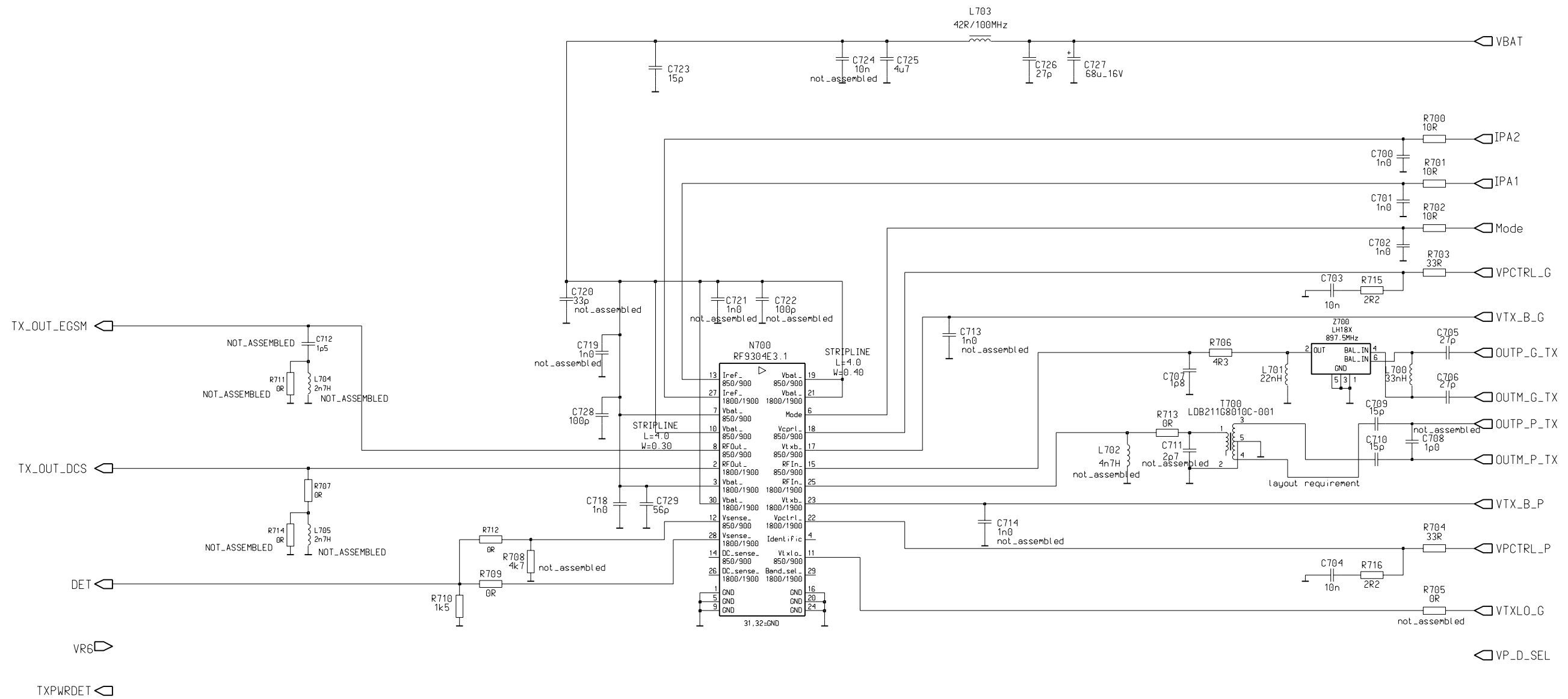

Last references :
 C731
 R714
 L705

BR4.5 Top Level, v. 6.1, ed. 29

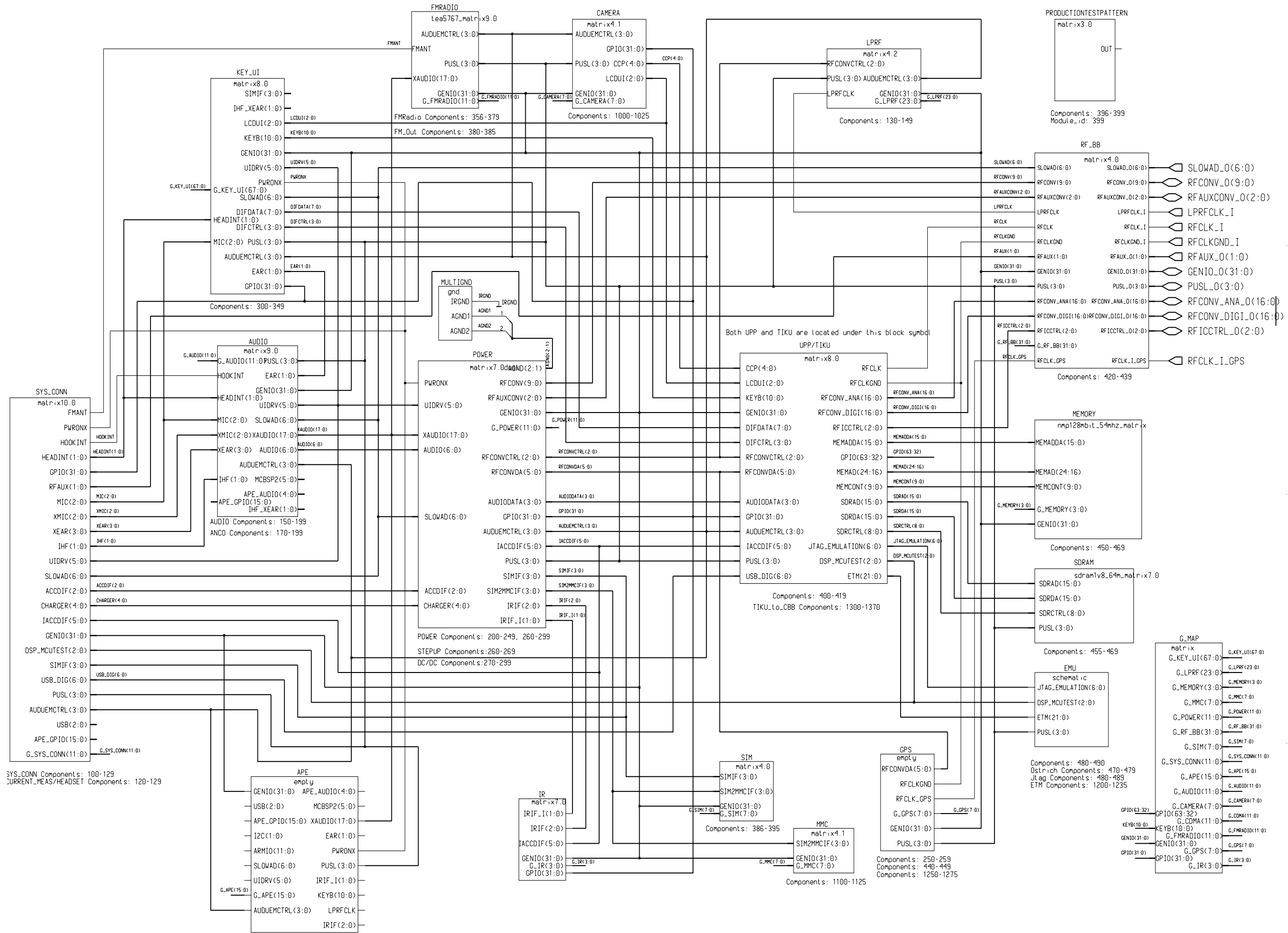

BR45 Audio, v. 1.6, ed. 167

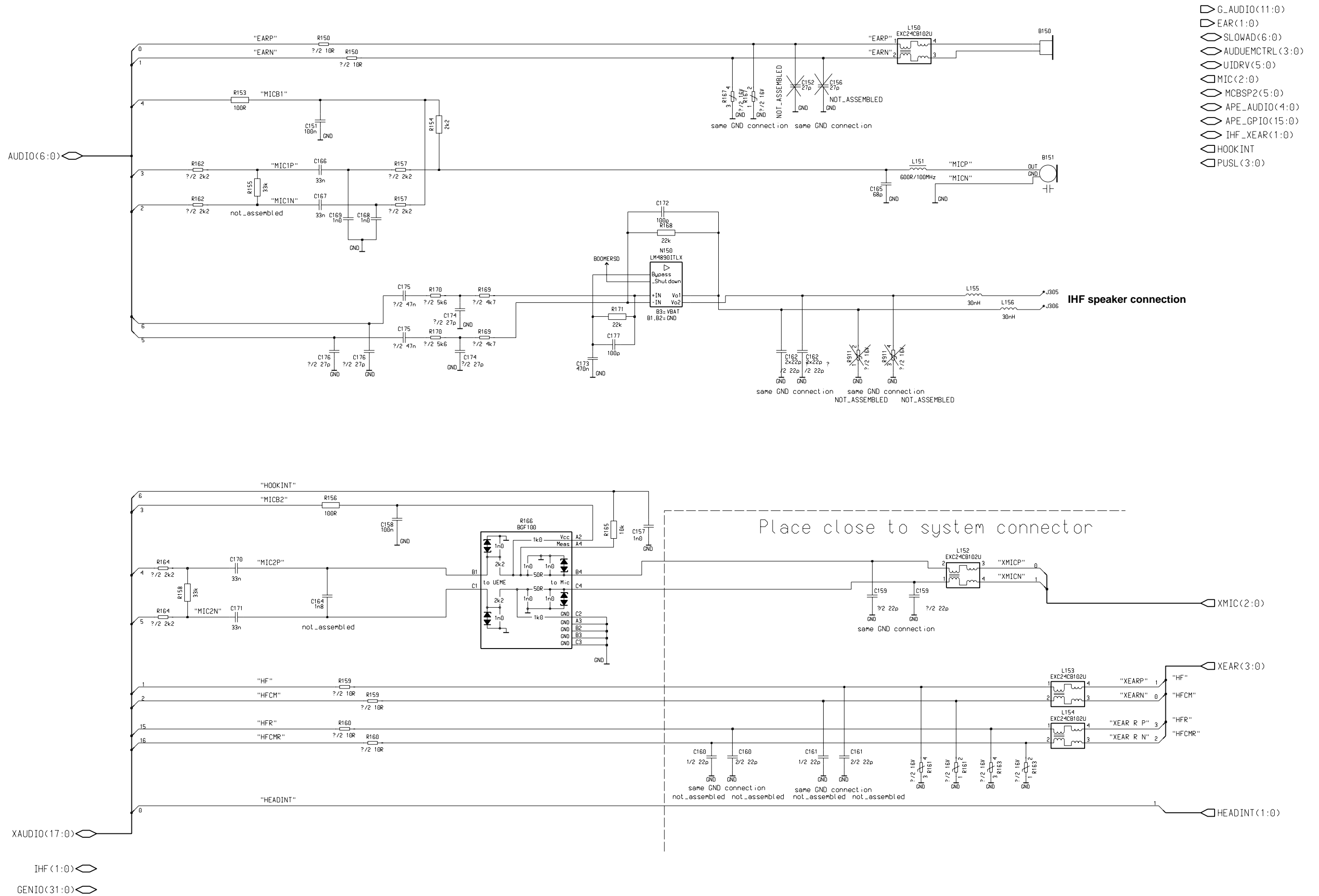

Mirage 2 VGA Camera, v. 1.1, Ed. 194

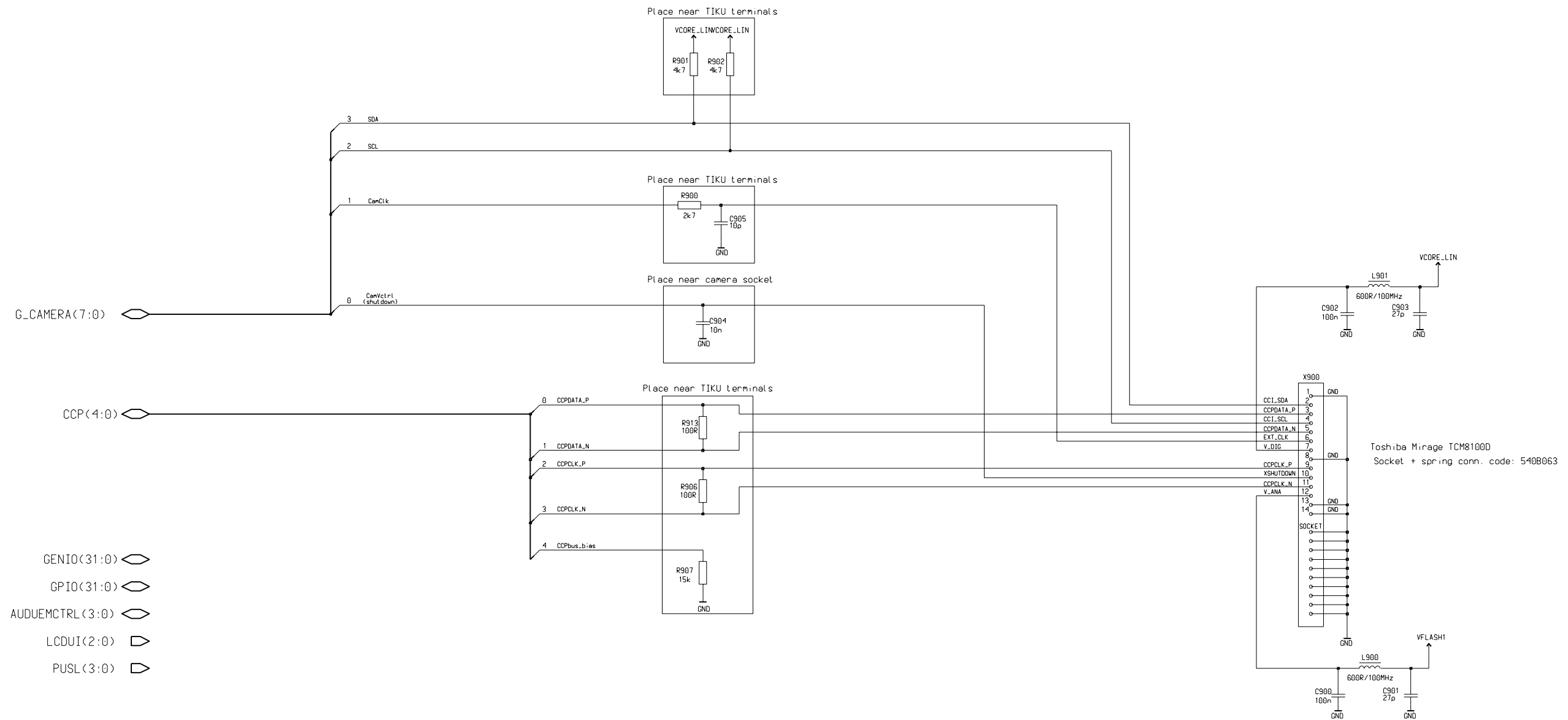

Test and Emulator Interface, v. 2.0, ed. 41

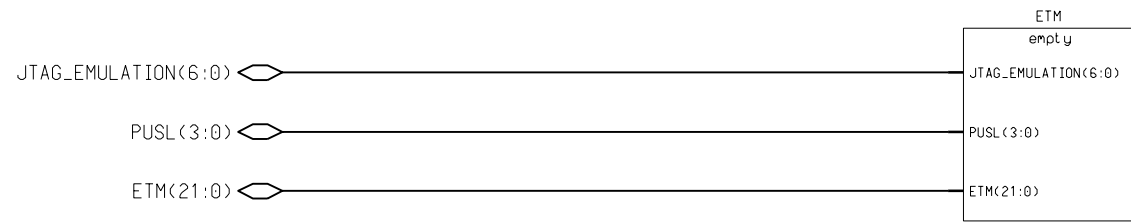

Testpoints for JTAG Emulator, v. 1.3, ed. 12

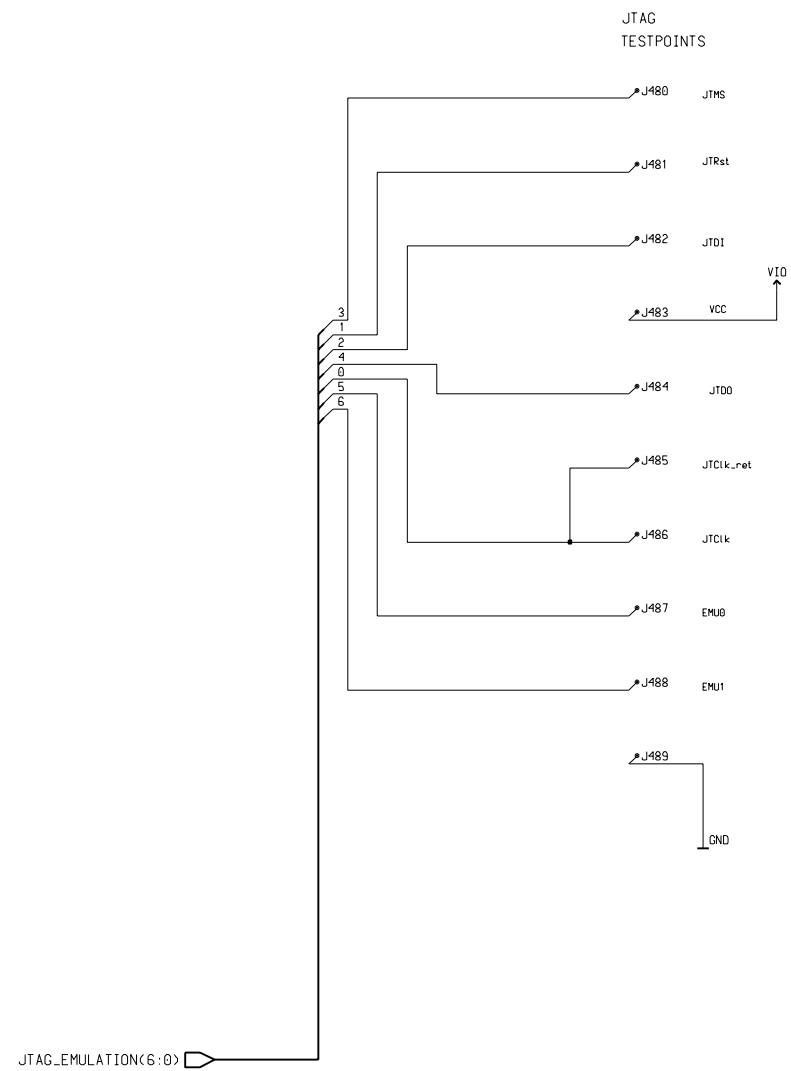

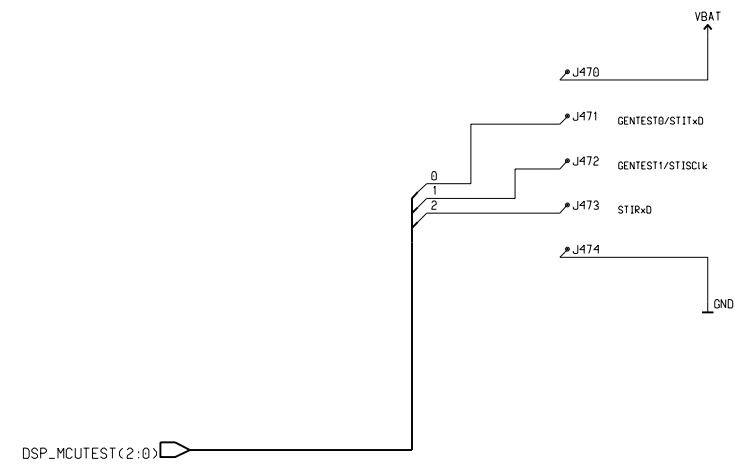

Testpoints Based Ostrich Interface, v.1.3, ed. 12

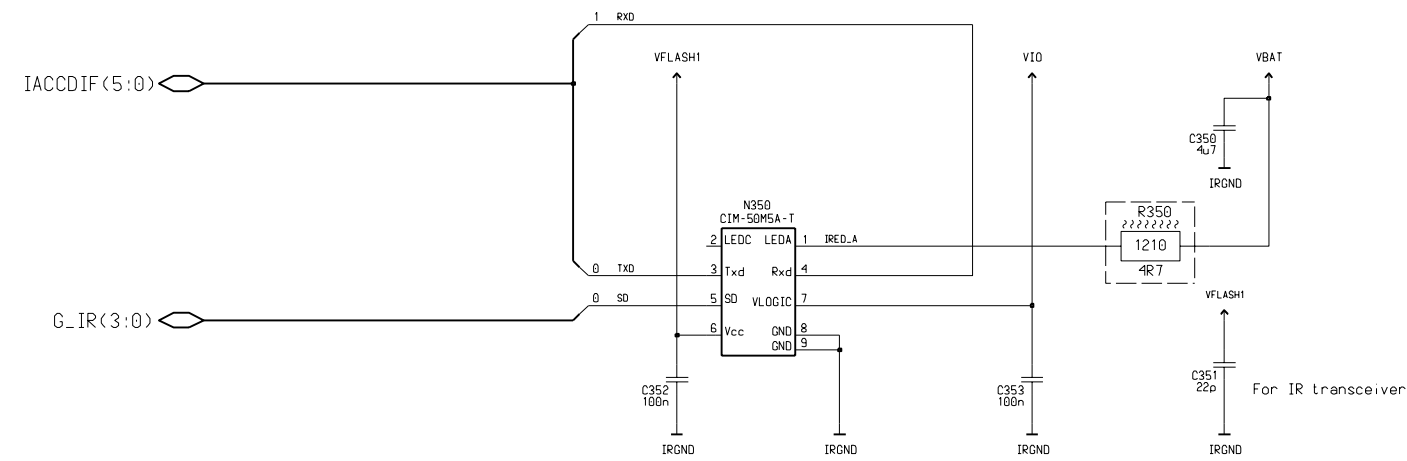

Citizen IR Module 1.8V, v. 6.1.8, ed. 55



GENIO(31:0) 
 GPIO(31:0) 

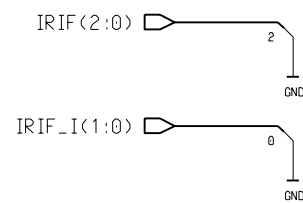

UEM IR level shifters
 are ground, when 1.8V
 IR is used!

Used referenses

- C 350 - 353
- N 350
- R 350

IR Resistor 1210, v. 0, ed. 6

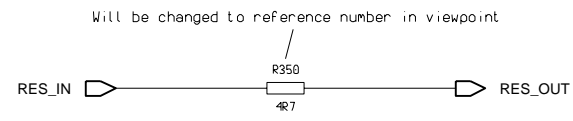

Key UI, v. 1, ed. 326

- MIC<2:0>
- PUSL<3:0>
- AUDUEMCTRL<3:0>
- LCDUI<2:0>
- EAR<1:0>
- HEADINT<1:0>
- SIMIF<3:0>
- IHF_XEAR<1:0>
- SLOWAD<6:0>
- GENIO<31:0>
- KEYB<10:0>
- GPIO<31:0>

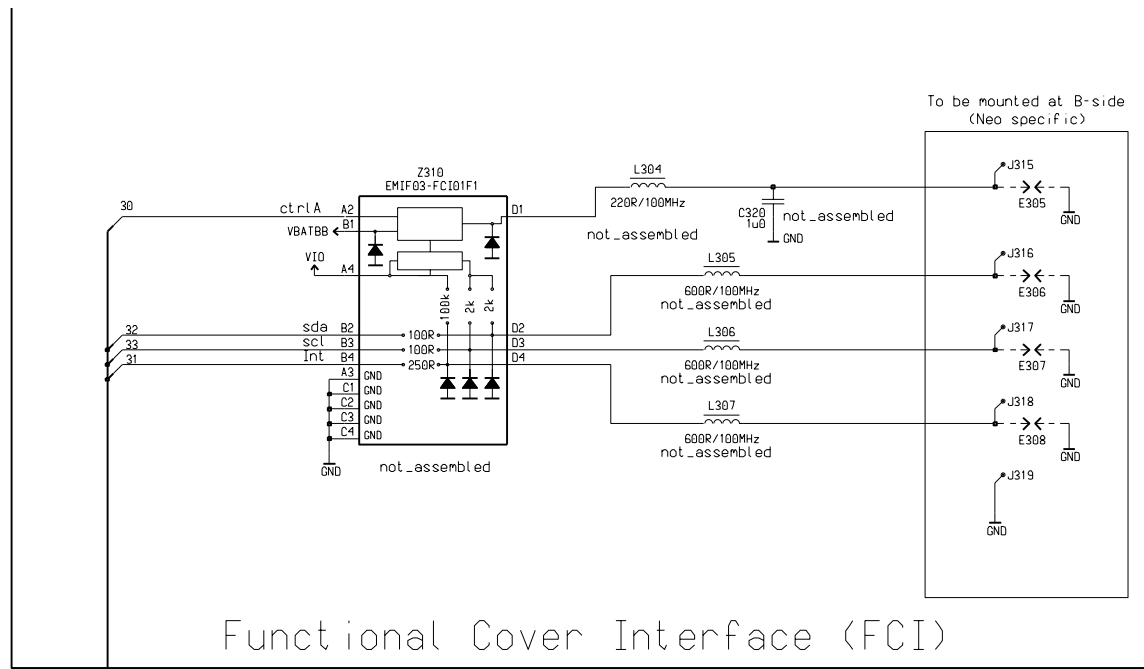
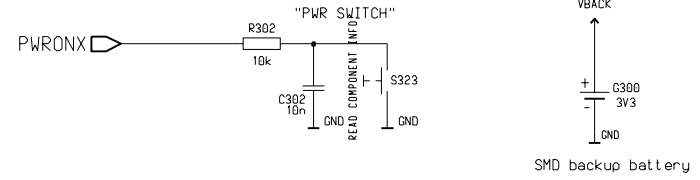

Functional Cover Interface (FCI)

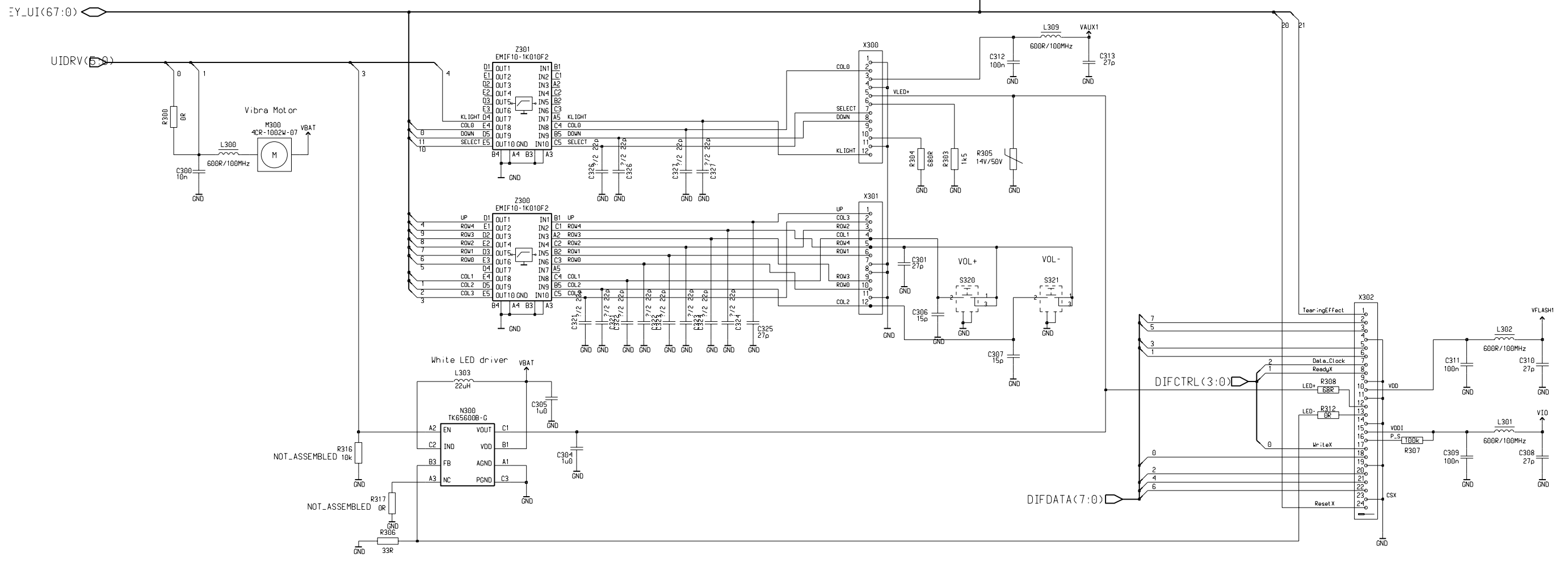

Flash Memory 128 Mbit, v. 2.0, ed. 74

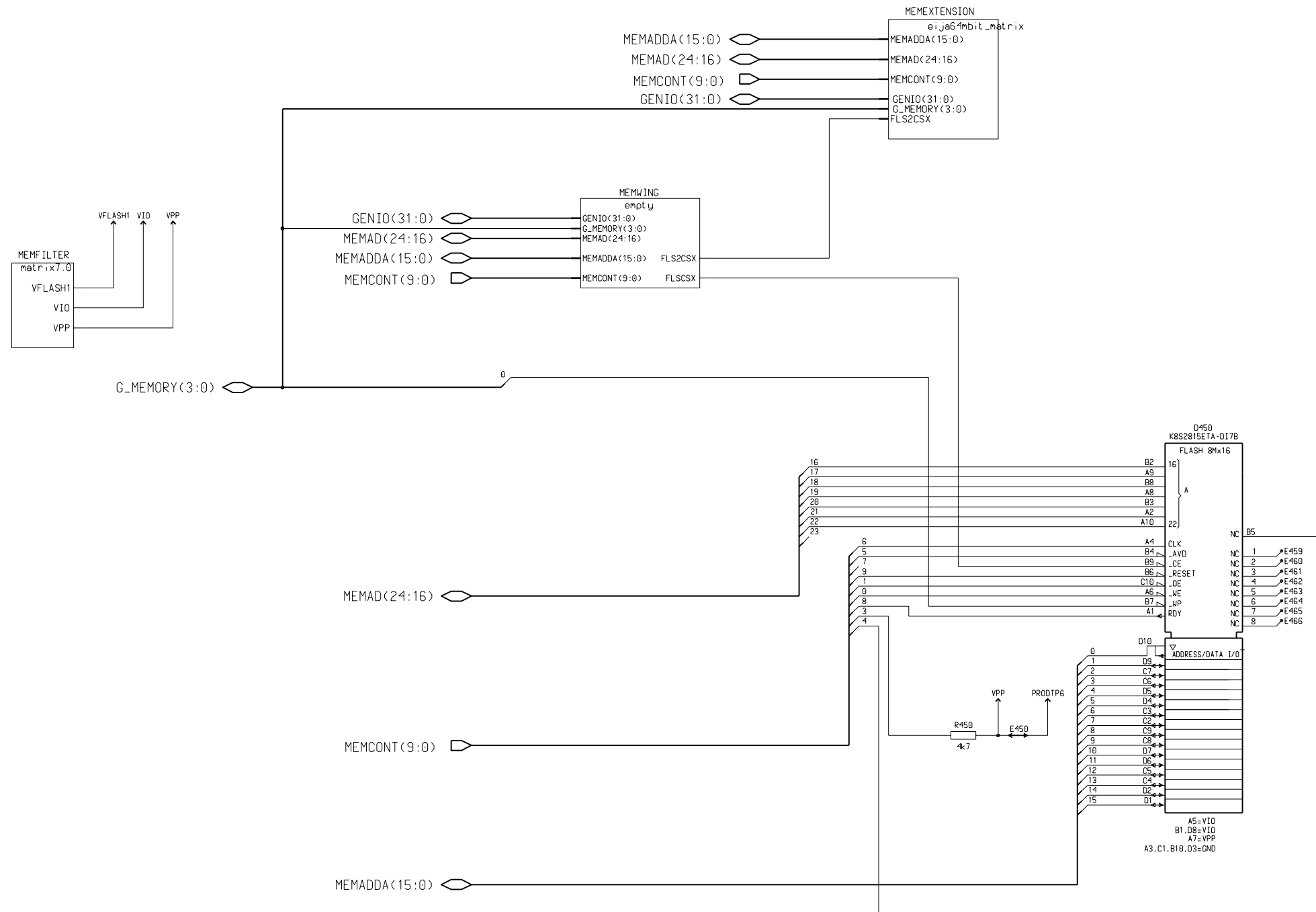

Discrete Capacitors for two Memories without VFlash1, v. 1.3, ed.11

Decoupling capacitors for 1st flash



Decoupling capacitors for 2nd flash

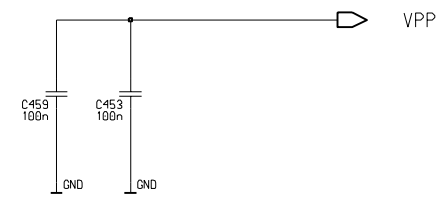
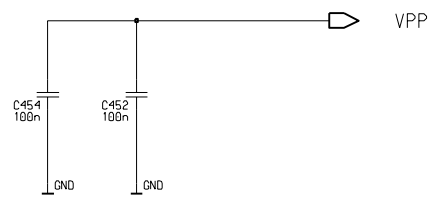
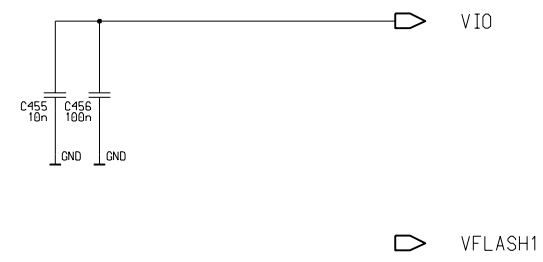

Empty Wing Sheet, v. 0, ed. 10

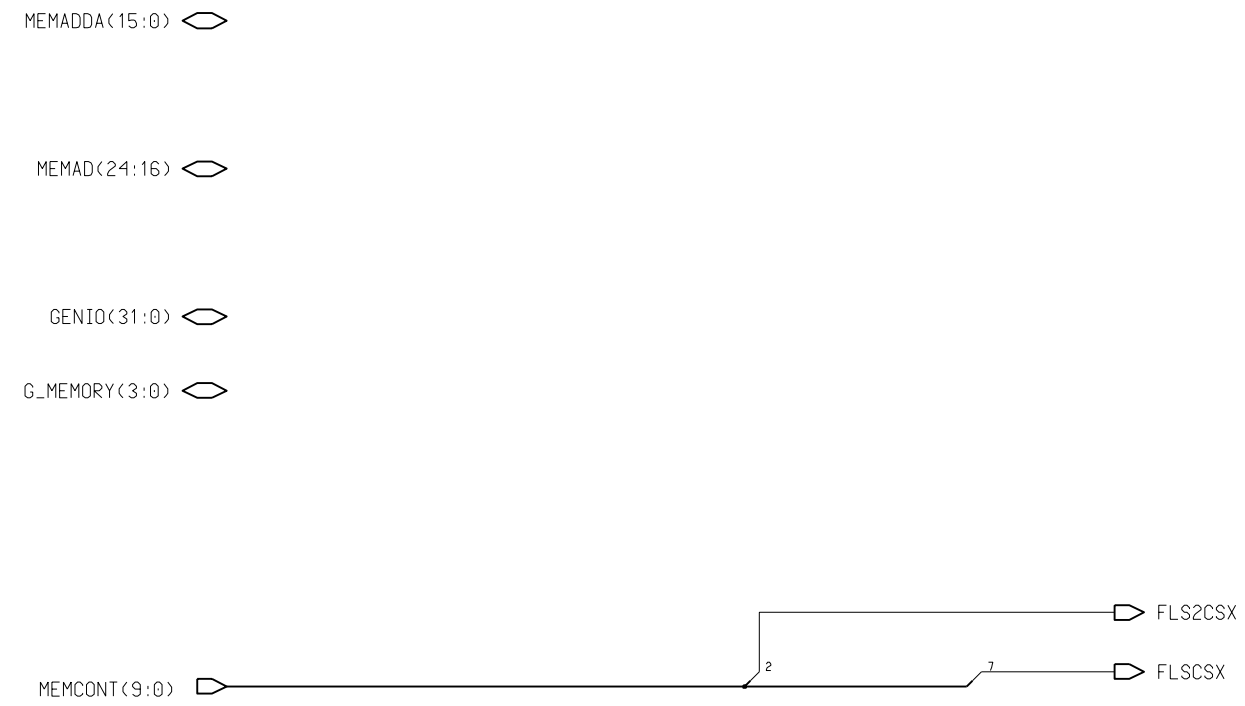

E915

MMC Interface, v. 2.1, ed. 79

GENIO<31:0>

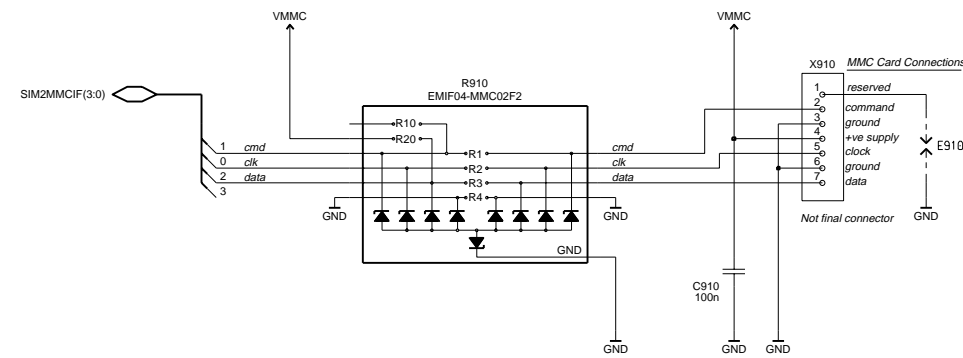

NOTE: The MMC specification imposes the following impedance limits
 Command pullup resistance 4.7k to 100k
 Data pullup resistance 50k to 100k
 EMIF02-MMC R10=13k (therefore only suitable for command line)
 EMIF02-MMC R20=56k (therefore only suitable for data line)
 EMIF02-MMC R1/R2/R3/R4=47R
 UEME includes a 13k pullup between GEN28IO2 (command) and VALX1
 so EMIF02-MMC R10 is left unconnected. UEME has no pullup on GEN28IO3 (MMC data)

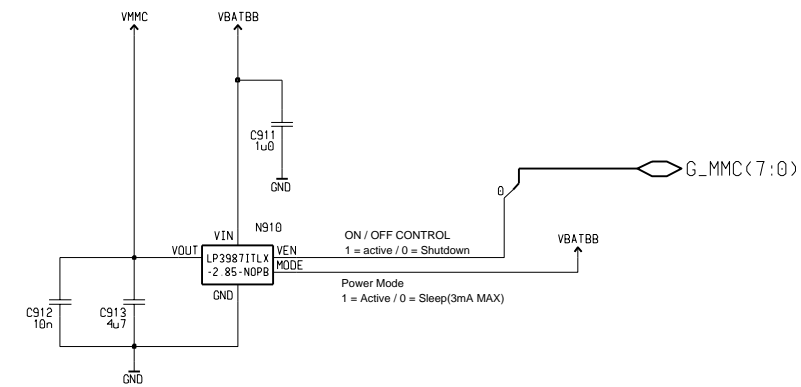

UEME Power Management - Dual 1 uF 6V3 Capacitors, v 1.0, ed. 307

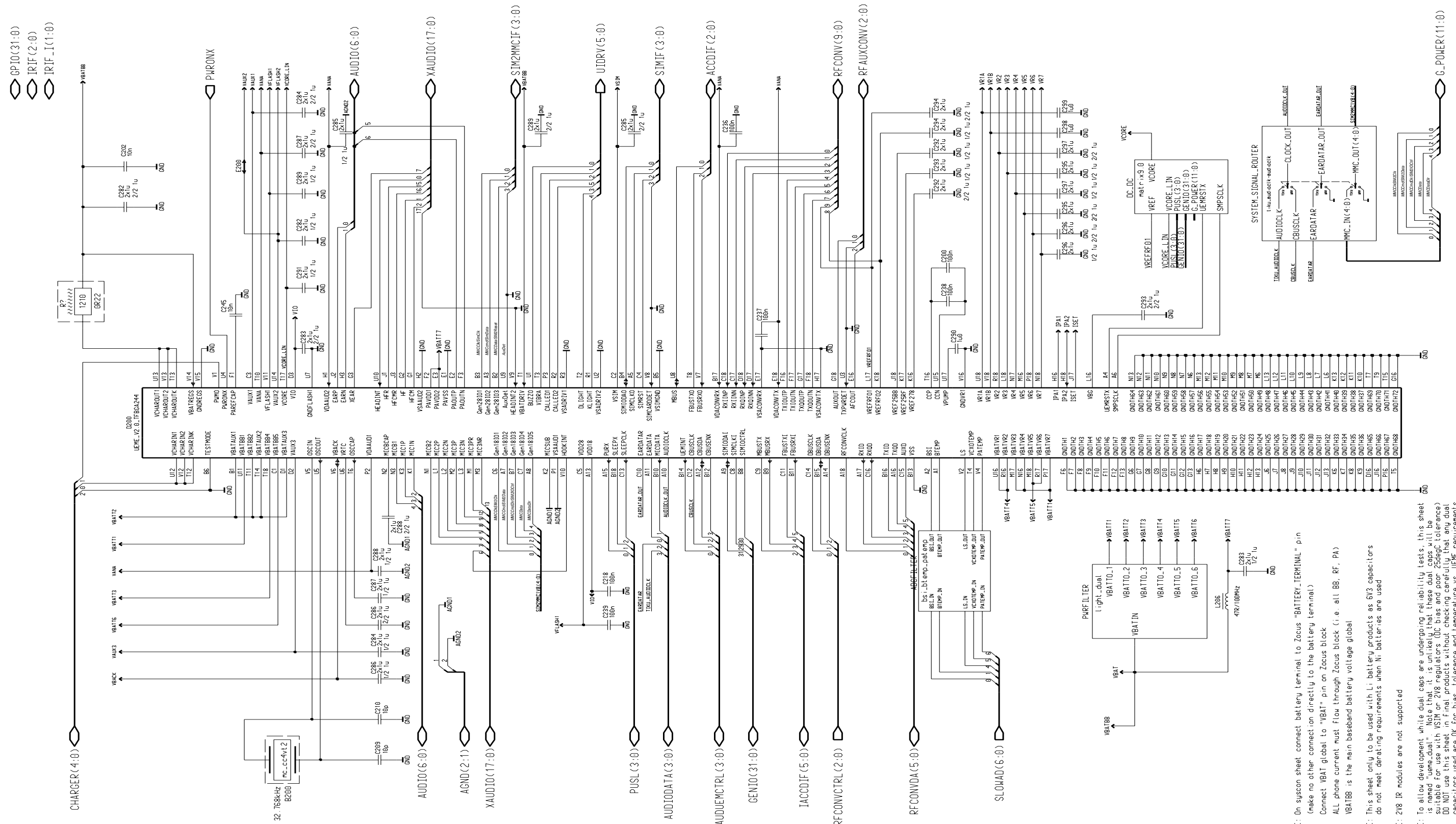

NOTE: On syscon sheet connect battery terminal to Zocus "BATTERY_TERMINAL" pin (make no other connect on directly to the battery terminal)
 Connect VBAT global to "VBAT" pin on Zocus block
 ALL phone current must flow through Zocus block (i.e. all BB, RF, PA)
 VBATBB is the main baseband battery voltage global

NOTE: This sheet only to be used with Li battery products as 6V3 capacitors do not meet derating requirements when Ni batteries are used

NOTE: V18 IR modules are not supported

NOTE: To allow development while dual caps are undergoing reliability tests, this sheet is named "ueme_dual". Note that it is unlikely that these dual caps will be available for use with V31R or V18 regulators (DC bias and poor ESR tolerance) DO NOT use this sheet in final products without checking carefully that any dual capacitors used are OK for bias, tolerance and temperature vs. UEME requirements

UEME ADC Filter Block - BSI, BTEMP and Active PATEMP, v. 1.0

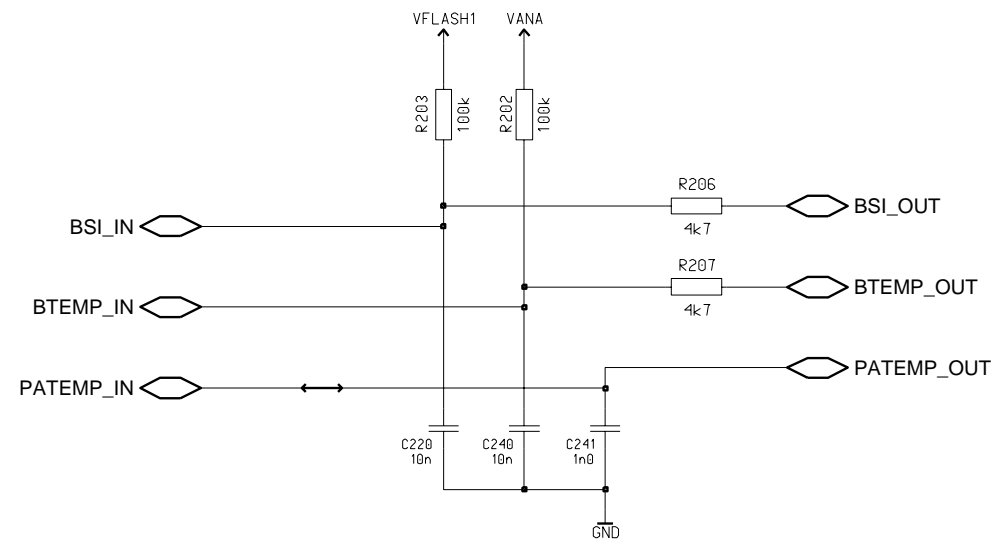

NOTE: Helga RF drives PATEMP directly
so PATEMP does not need a pullup

DC_DC for TIKU and VIO, v. 1.7, ed. 75

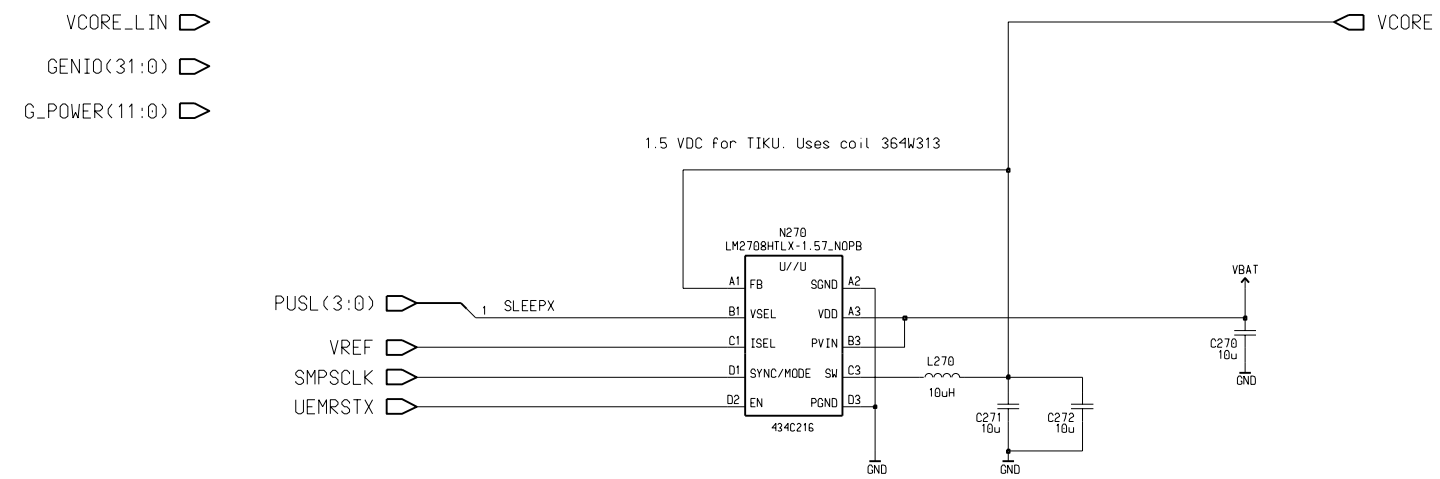

Light Filtering for Projects using 1uF Caps, v. 1.0

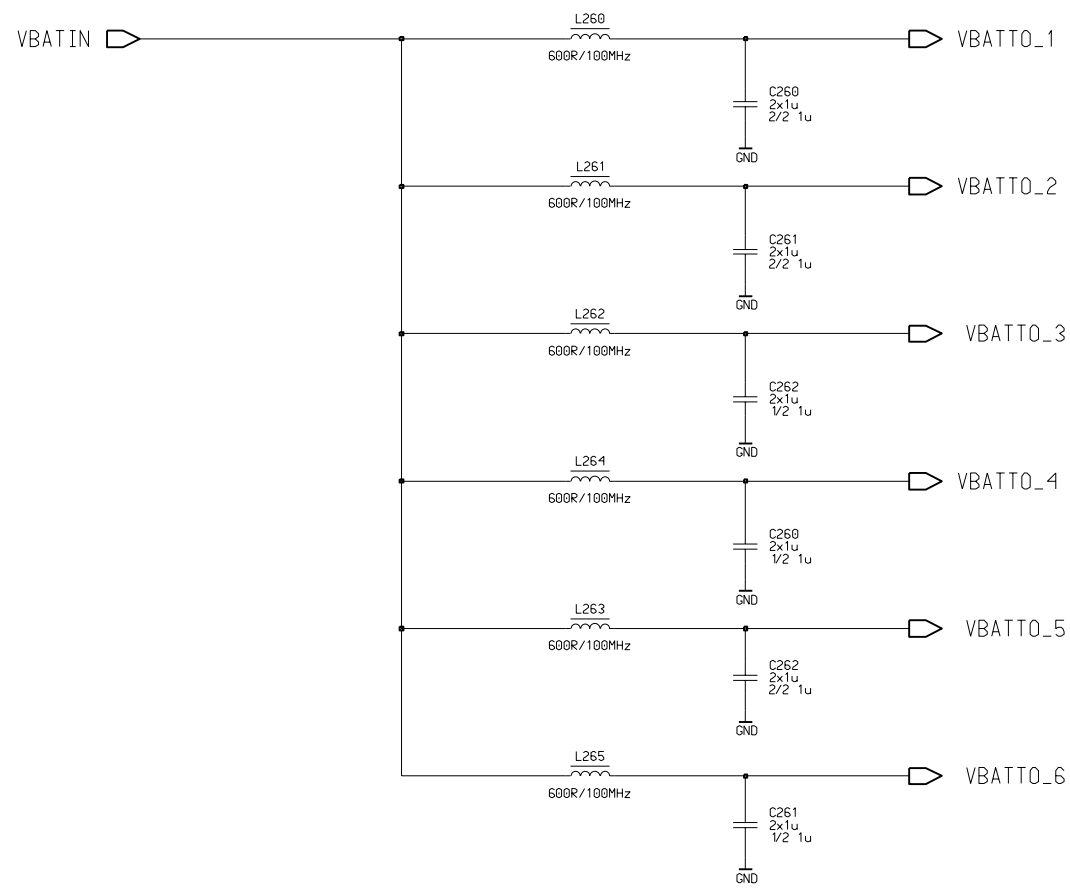

NOTE: This sheet uses dual 1uF capacitors. Check that full approval has been granted for these parts before use, or use this sheet at risk

Digital-ASIC-dependent Signal Routing - TikuXX Systems, v. 1.0

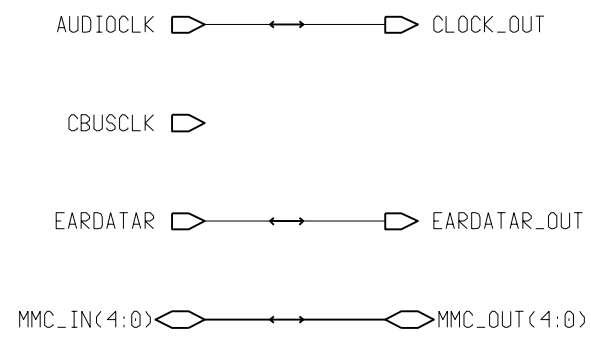

E916

32KHz Crystal - Micro Crystal CC4VT2, v. 0, ed. 6

Will be changed to reference number in viewpoint

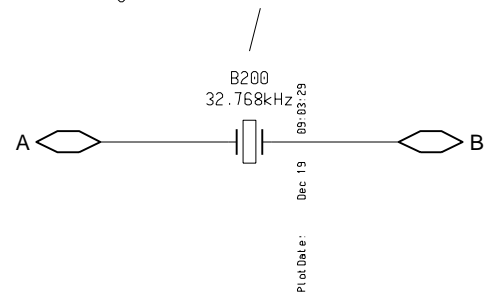

PWR Resistor 1210, v. 0, ed. 4

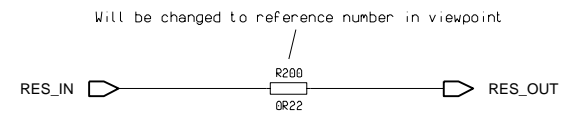

GSM RF - Baseband Interface, v. 1.3, ed. 64

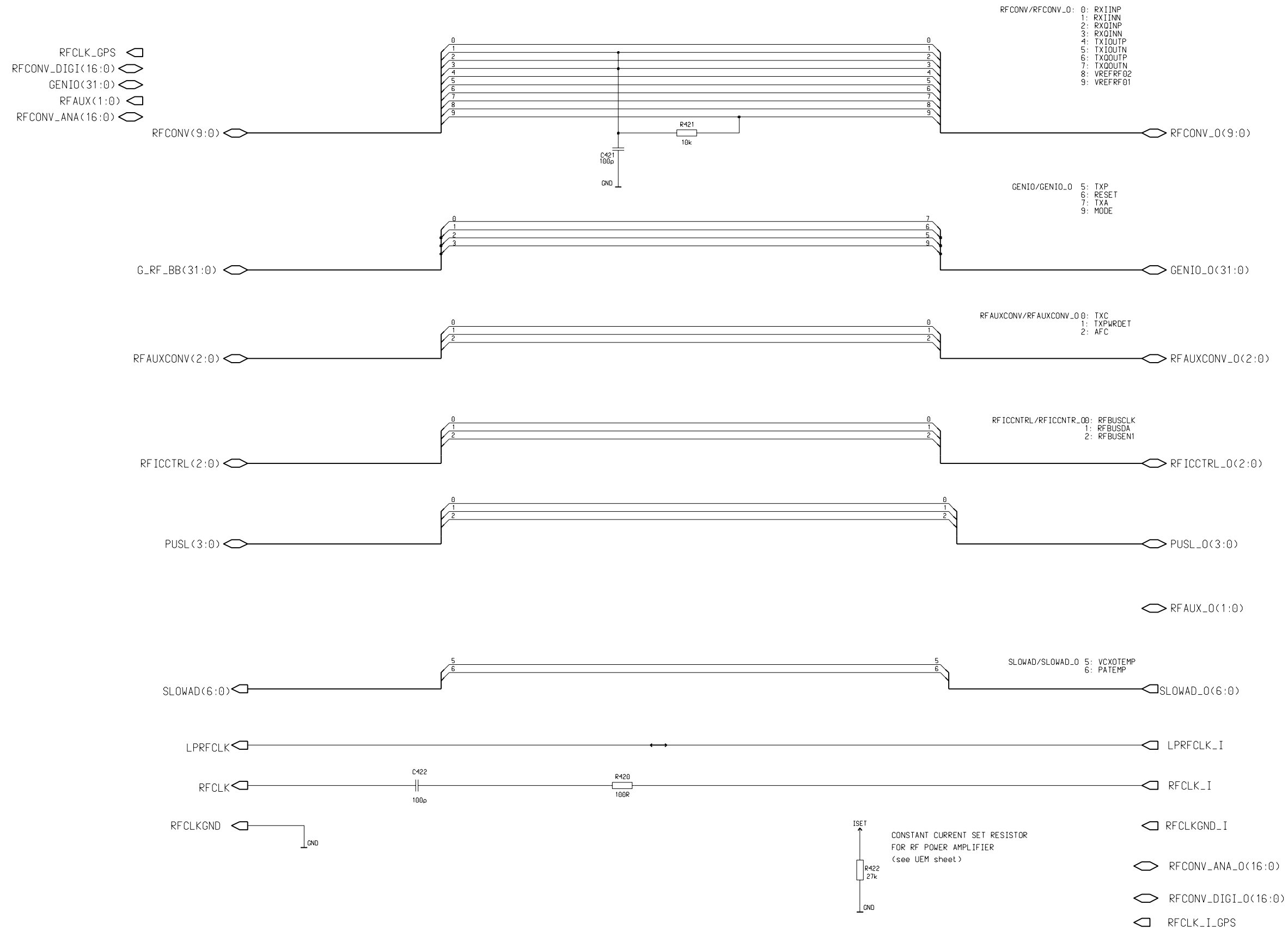

IPA1 AND IPA2 ARE USED IN RF, THE TOLERANCE OF R422 IS 1% (0402, 1430873)

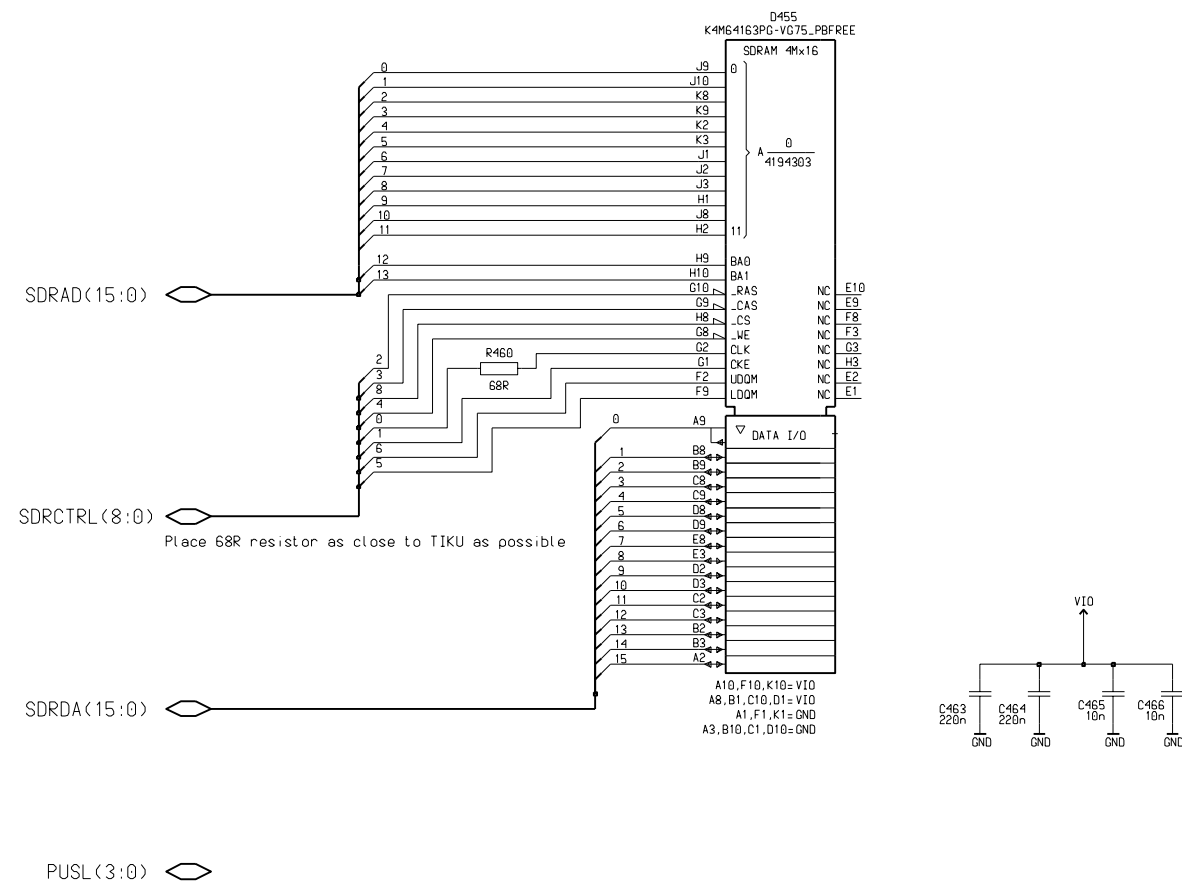

SIM Reader, v. 1.3, ed. 66

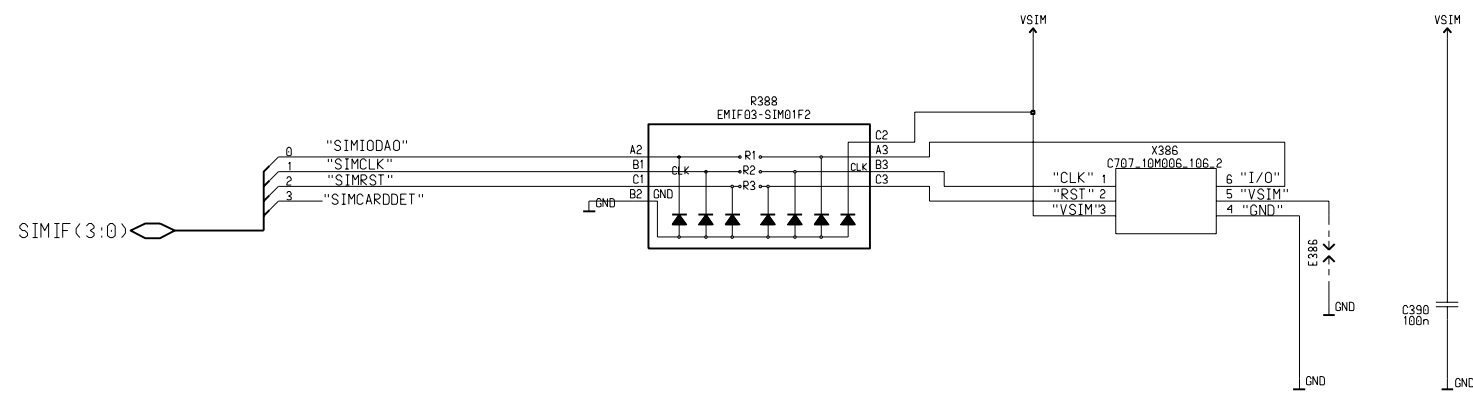

GENIO<31:0>

SIM2MMCIF<3:0>

G_SIM<7:0>

Current Measure, v. 0, ed. 18

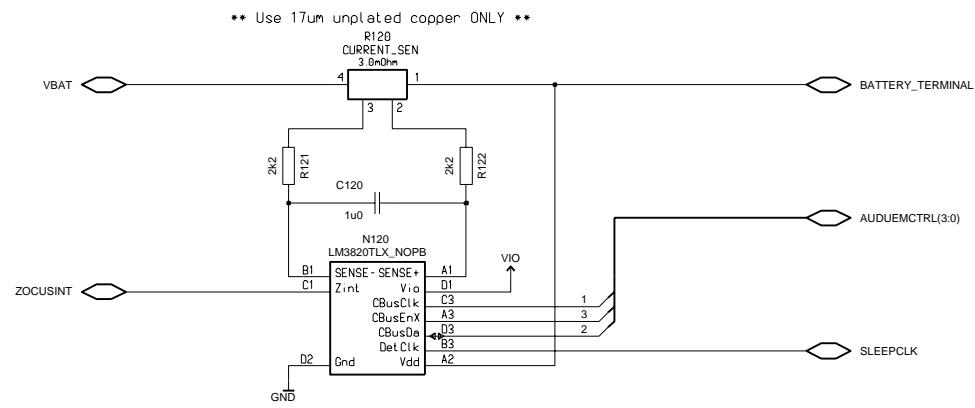

5 pin Production Test Pattern, v. 2.0, ed. 52

▷ OUT

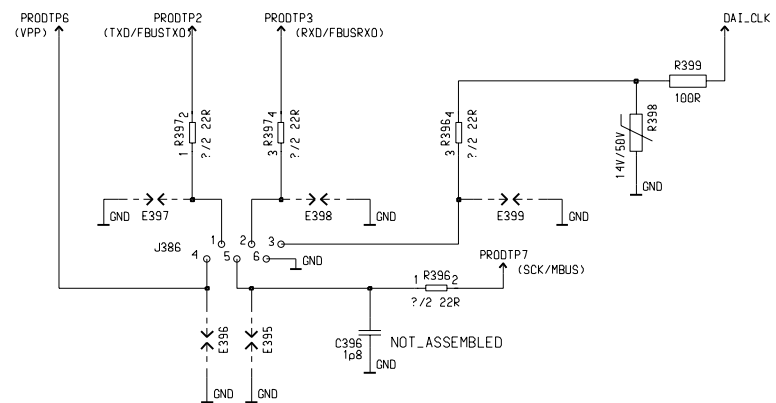

TIKUedge Implementation (GSM)

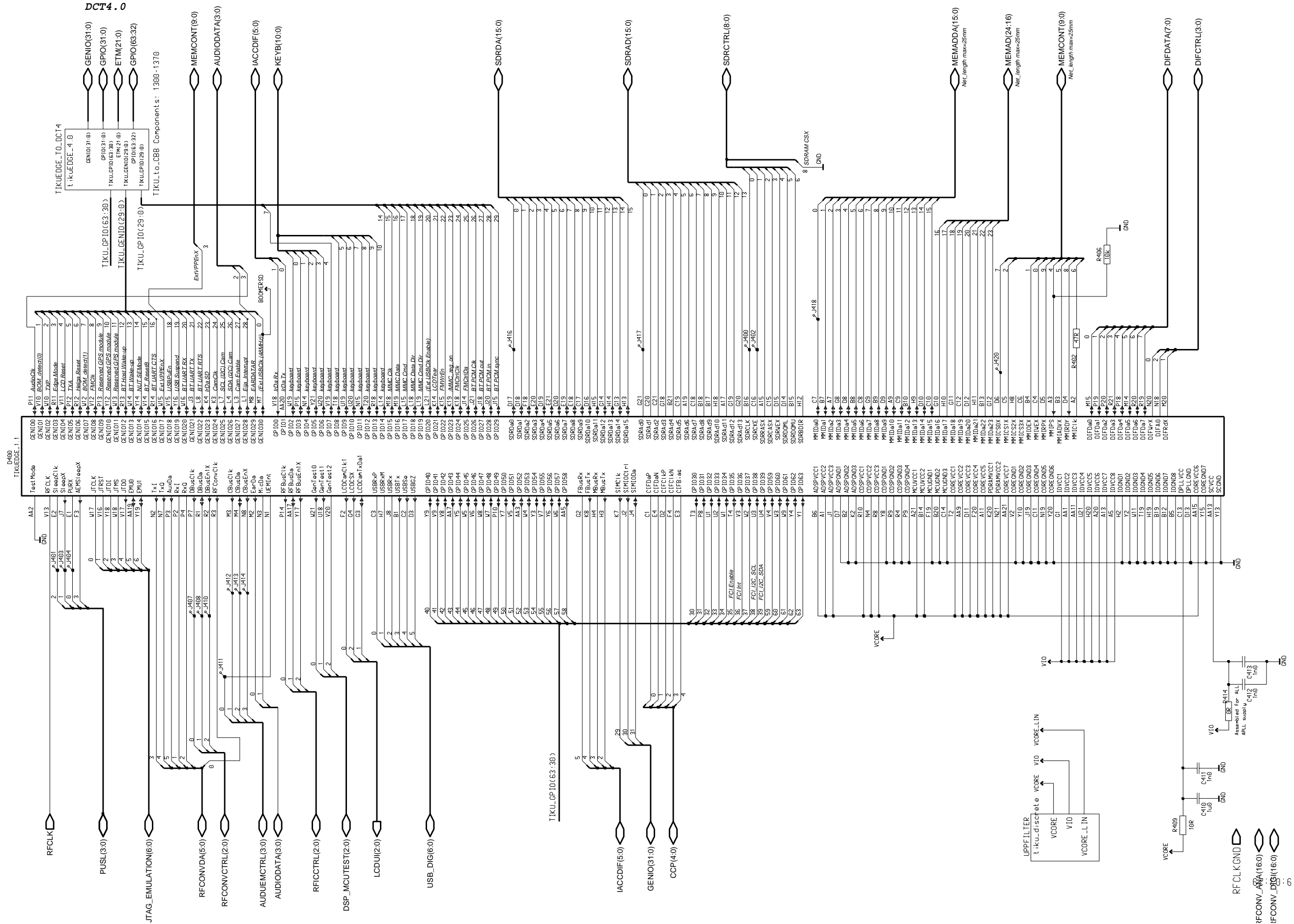

Discrete Decoupling Capacitors for Tiku, v. 0, ed. 12

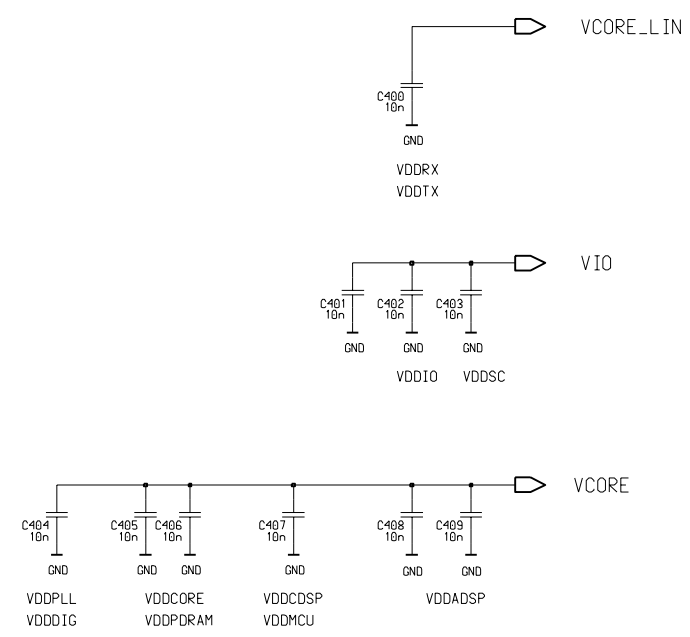

TikuEDGE Bus Conversion Sheet, v. 1.2, ed. 102

ETM(21:0)

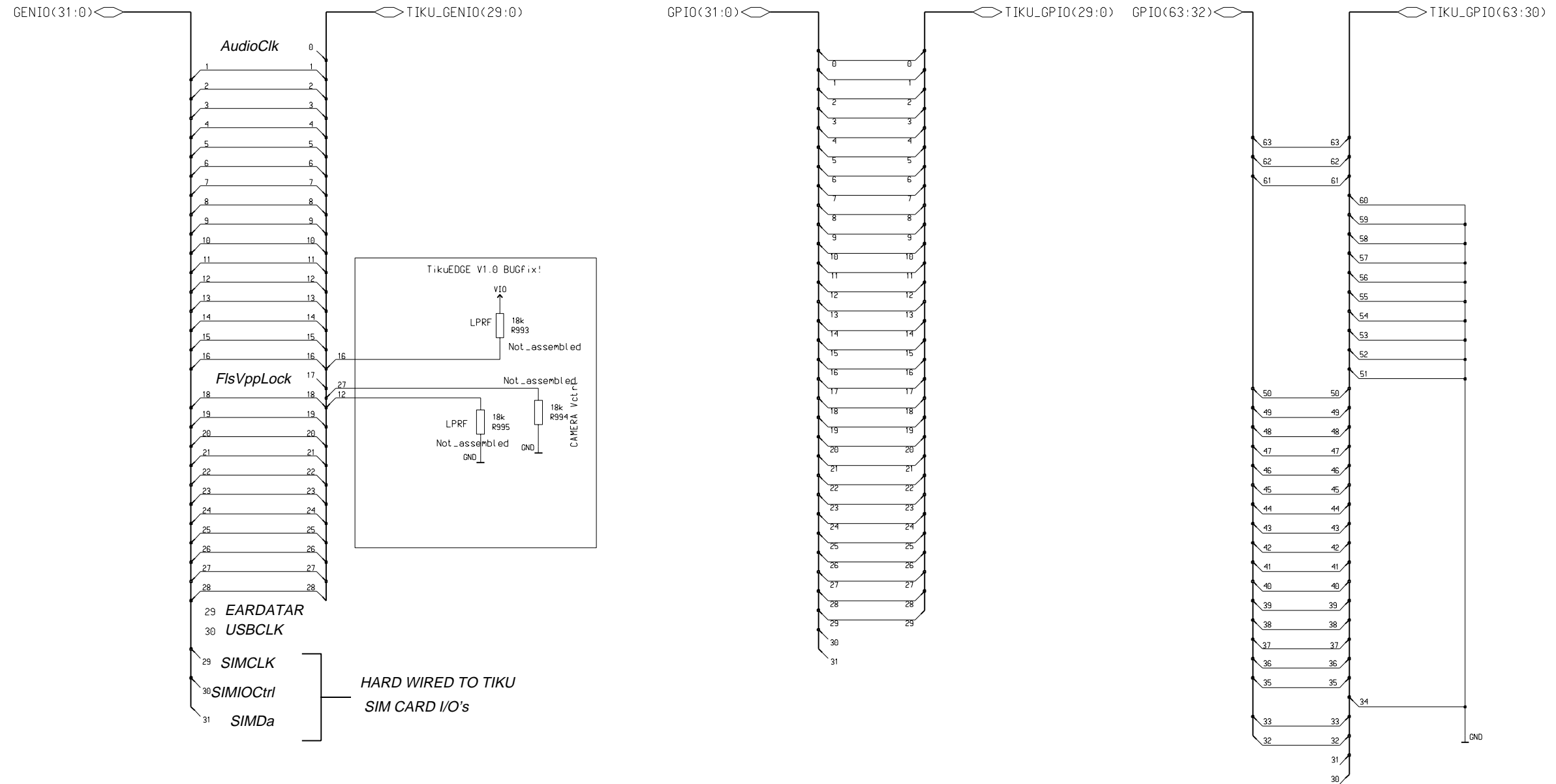

FM Radio Unit, v. 1.3, ed. 198

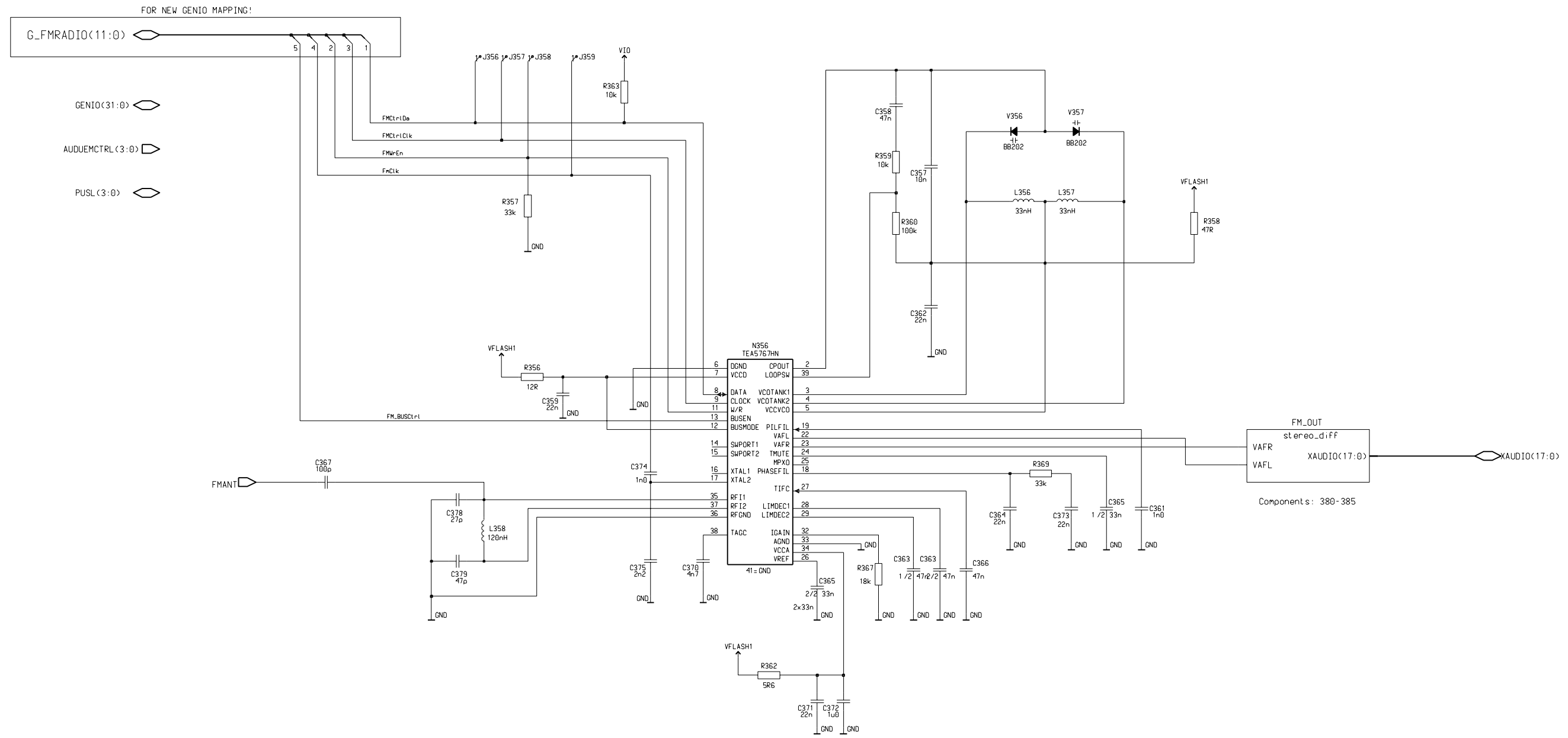

UPDATE symbol to support RDS

Notice:

C374 (1n0) and C375 (2n2) are configured for 32kHz reference clock
 If reference clock is 6.5MHz, use C374 (3p9) and C375 (10p)

Differential Stereo. v. 0.0, ed. 7

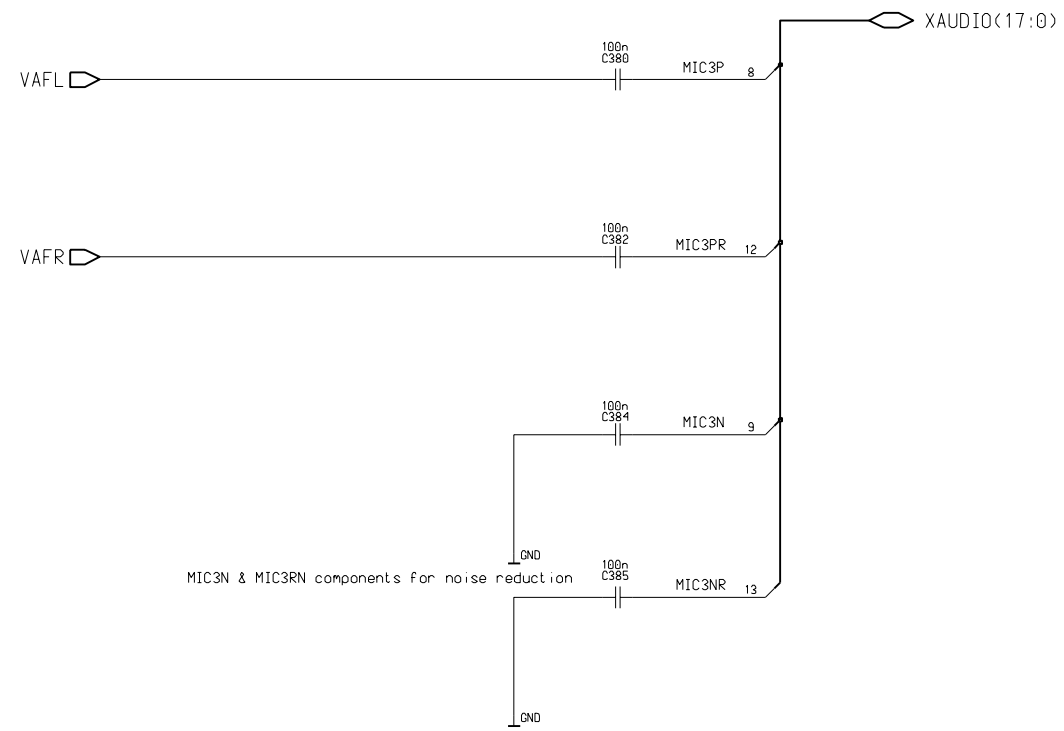

GENIO and GPIO Connection Block, v. 0.0, ed. 38

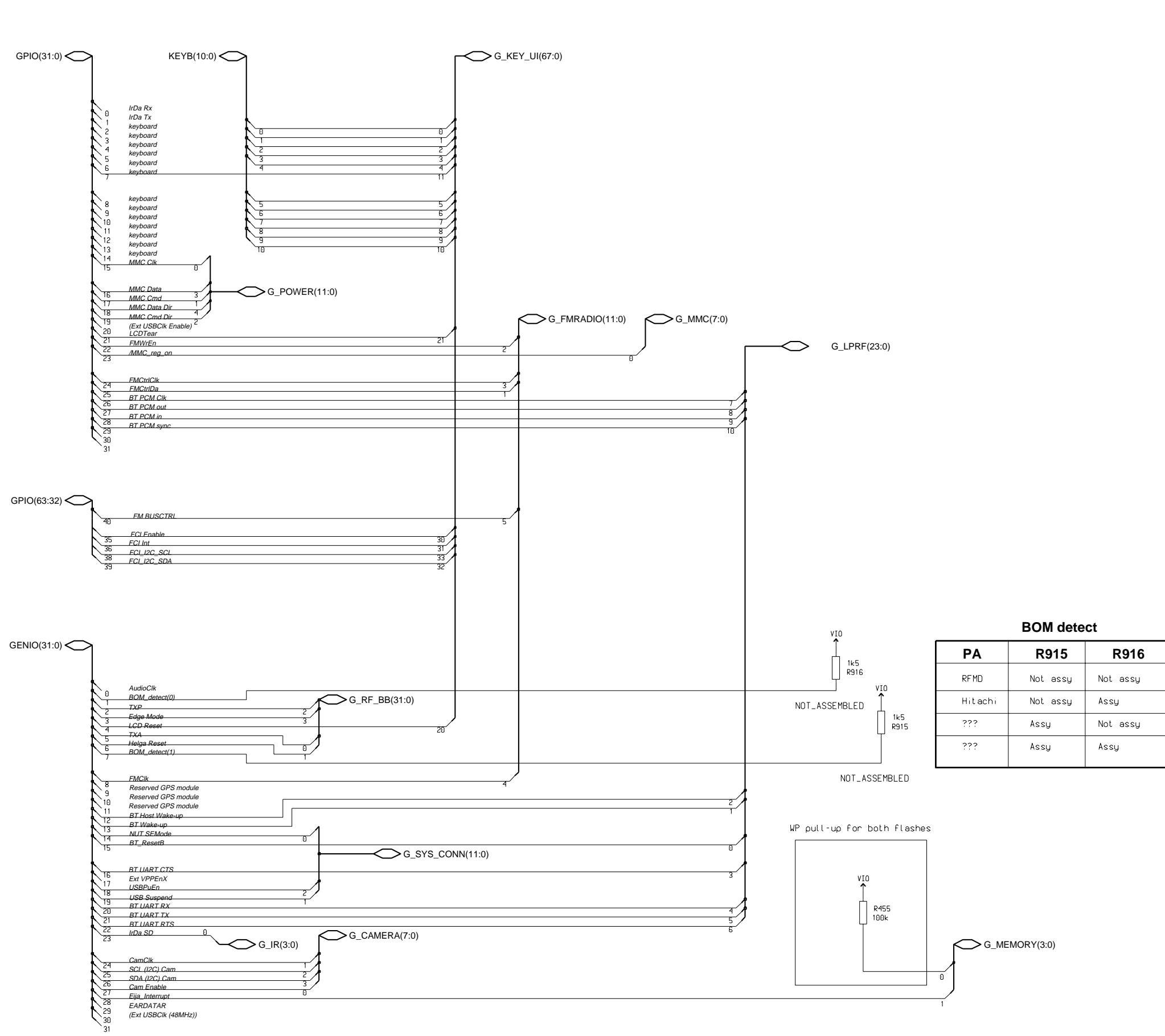

- G_AUDIO(11:0)
- G_APE(15:0)
- G_CDMA(11:0)
- G_GPS(7:0)
- G_SIM(7:0)

BOM detect

PA	R915	R916
RFMD	Not assy	Not assy
Hitachi	Not assy	Assy
???	Assy	Not assy
???	Assy	Assy